



Industrial Devices Corporation

Right Angle Spur Gearhead

Installation Instructions

This carton contains the following parts along with this instruction sheet:

- IDC Right Angle Spur Gearhead
- Pinion Gear
- Balanced Clamp Collar
- Four Motor Mounting Screws
- Woodruff Key
- Allen Wrench(es)

You will also need these tools (see table below):

- A torque wrench with an Allen driver to tighten the clamp screws
- A feeler gage or gage pin to set the pinion spacing

Gearhead Size	Clamp Screw Size	Clamp Screw Torque	Pinion Spacing Gage
G23	6-32	12 in-lbs [1.3 N-m]	0.047 in [1.2 mm]
G34	6-32	12 in-lbs [1.3 N-m]	0.047 in [1.2 mm]
G42	1/4-28	110 in-lbs [12 N-m]	0.094 in [2.4 mm]
G56	1/4-28	110 in-lbs [12 N-m]	0.094 in [2.4 mm]

ASSEMBLY PROCEDURE

1. Slide the clamp collar onto the pinion gear up to the shoulder. Rotate the clamp collar so that the slots in the pinion gear line up with the slots in the collar. (figure 1, over)
2. Gently tighten the clamp screws to take up the clearance between the pinion and collar. Keep the gaps on the clamp collar approximately the same size.
3. Slide the pinion gear and clamp assembly onto the motor shaft.
4. Set the spacing between the motor pilot face and the pinion gear using a pin or feeler gage of the size shown in the table above. (figure 2, over)
5. Tighten the clamp screws firmly and remove the pin or feeler gage.
6. **IMPORTANT** - torque the clamp screws as shown in the table above.
7. Set the motor/pinion assembly vertically on your work table with the pinion gear at the top.
8. Gently lower the gearhead onto the motor shaft and rotate it so that the pinion meshes with the gear and the gearhead sits flush on the motor. Line up the holes in the motor flange with the holes in the gearhead flange, making sure the motor leads are oriented in the preferred position.
9. Lay the assembly flat on the work surface, install the motor mounting screws and tighten with the Allen wrench.

NOTE

If the gearhead is to be operated with the motor shaft up, in or near a vertical position, and you did not specify the -V option, call IDC for further instructions.

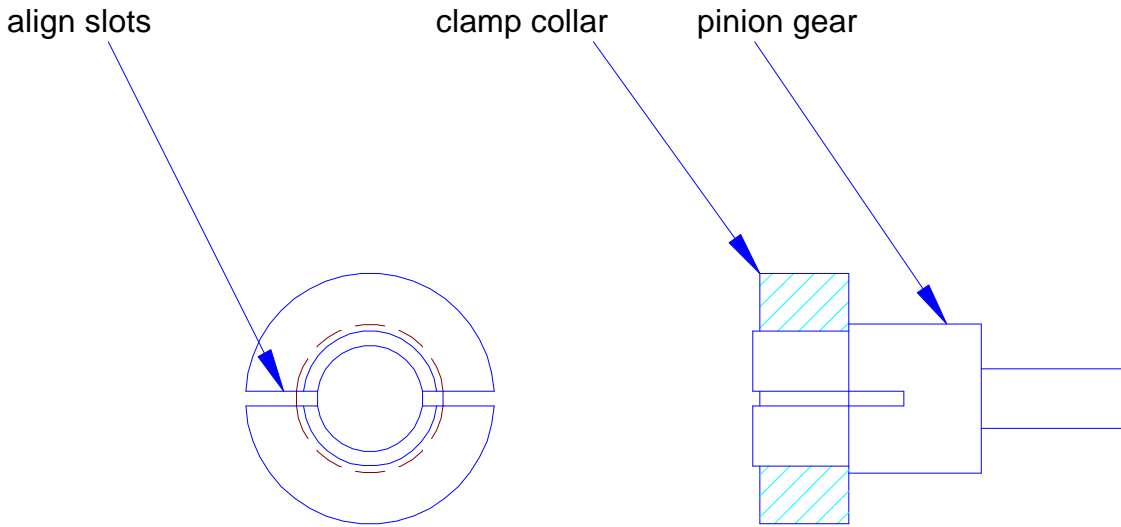

figure 1

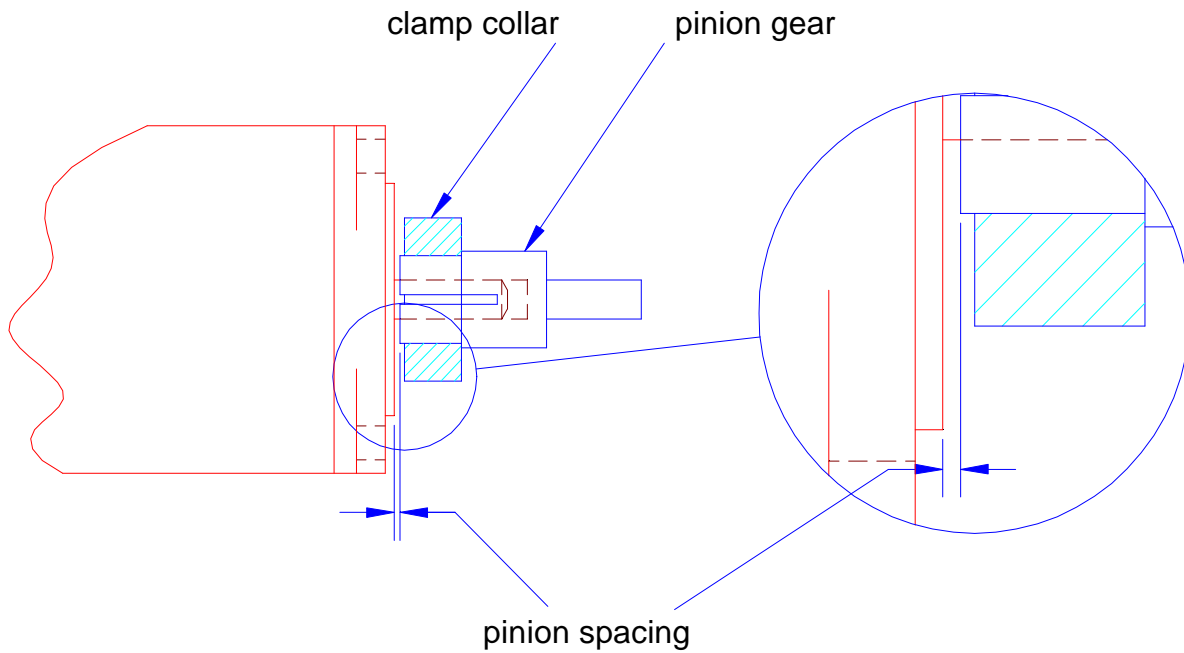

figure 2